

Assembly Sketch

YB-25-P50 Clamp Kit Stainless Steel

(can be used with UV1-SS Clamp)

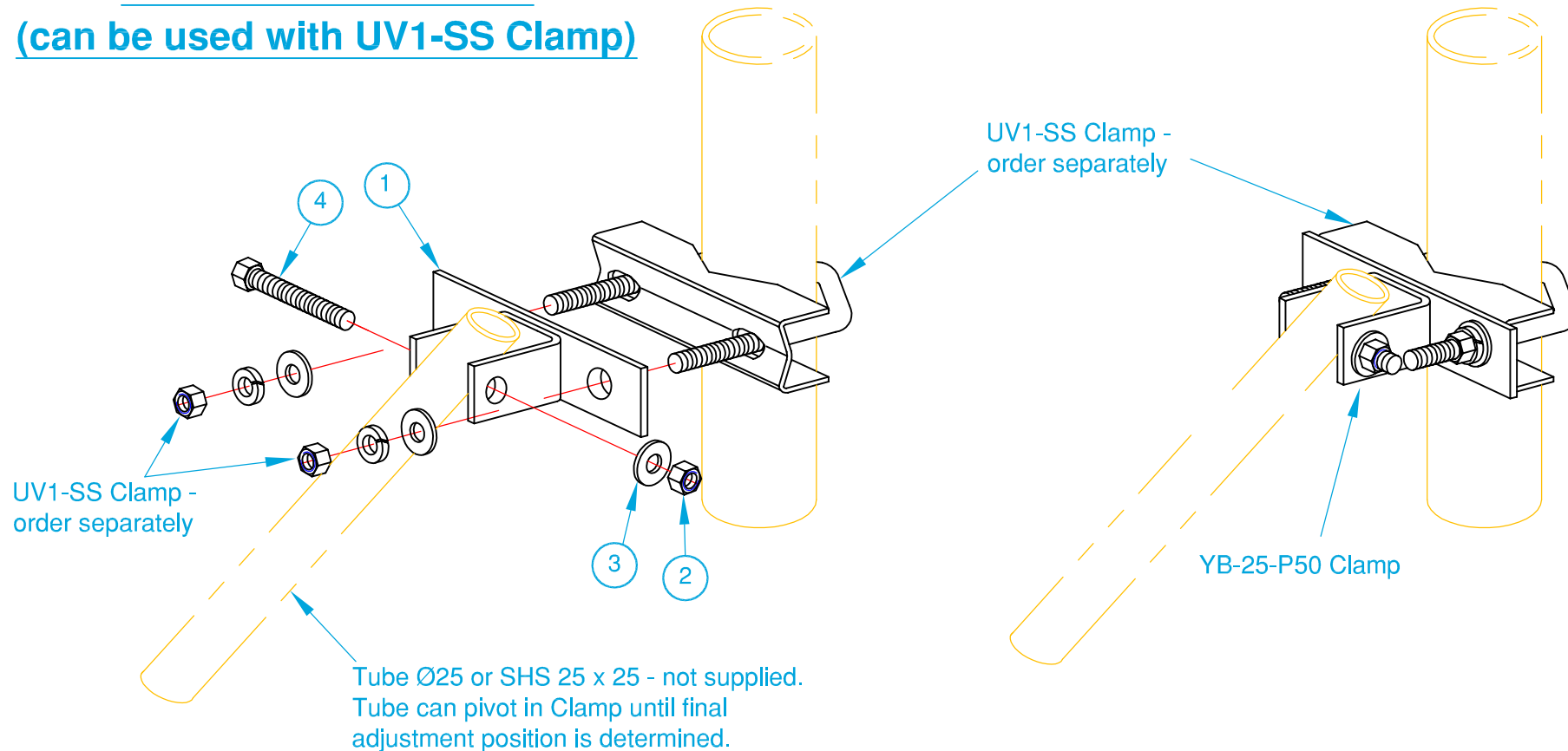

PARTS SUPPLIED:

4	Bolt, Hex Head, M8 x 50, Stainless Steel Gr. 304	1
3	Washer, Flat, M8, Stainless Steel	1
2	Nut, 'Nyloc', M8, Stainless Steel Gr. 316	1
1	YB-25-P50 Clamp Body, Stainless Steel	1
Item	Description	Quantity.

G-Tech Communication Services Pty. Ltd. Trading as :

ZCG SCALAR®

DESIGNERS AND MANUFACTURERS OF RADIO FREQUENCY ANTENNAS

Hall Street, Lindenow, Victoria, Australia.
Tel: (03) 5157 1203 Fax: (03) 5157 1641

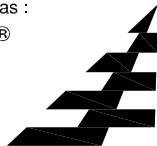

Copyright - G-Tech Communication Services Pty. Ltd. No part of this Drawing is to be reproduced without Written Authority

1523-4-B.dwg LM 16-10-14

Approved: